

# 5-7.5t K series

Internal Combustion  
Counterbalanced Forklift Truck



## PT. BADAK PRIMA LESTARI

Kawasan Industri Millenium, Jl. Millenium 15 Blok I-2 No. 3A, Desa Peusar,  
Kecamatan Panongan, Kabupaten Tangerang, Banten 15710 INDONESIA

Tel: +62 59986616 / 30 , Fax.: +62 59986847

[www.badakprima.co.id](http://www.badakprima.co.id)

**HELI**  
LIFTING THE FUTURE

# 5-7.5 t K series internal combustion counterbalanced forklift truck



## Characteristics

1	Manufacturer		HELI		
2	Model		CPCD50	CPCD60	CPCD70
3	Power Unit		Diesel		
4	Rated Capacity	Q(kg)	5000	6000	7000
5	Load Center	C(mm)	600		
6	Operation		Driver Seated		
7	Overall Max.Lifting Height (with backrest)	h4(mm)	4400		
8	Max.Lifting Height	h3(mm)	3000		
9	Free Lift Height	h2(mm)	200		
10	Height Mast Retracted (upright)	h1(mm)	2500		

## Dimensions

11	Overall Height (overhead guard)	h6(mm)	2450		
12	Overall Length (with forks)	L1(mm)	4625	4700	4780
13	Overall Length (without forks)	L2(mm)	3405	3480	3560
14	Overall Width	B(mm)	1995		
15	Front Overhang	X(mm)	590	595	600
16	Rear Overhang	L4(mm)	565	635	710
17	Wheel Base	L5(mm)	2250		
18	Min. Ground Clearance Under Mast	m1(mm)	200		
19	Tread (front/rear)	S/P(mm)	1470/1700		
20	Outside Turning Radius	Wa(mm)	3250	3300	3360
21	Min. Intersecting Aisle	Ra(mm)	2960	3000	3040
22	Tilting Angles (forward/backward)	$\alpha / \beta (^{\circ})$	6° / 12°		
23	Fork Dimensions (a x b x c)	mm	55x1220x150	60x1220x150	65x1220x150

## Performance

24	Max. Travelling Speeds (laden/unladen)	km/h	26/29		
25	Lifting Speeds (laden/unladen)	mm/s	510/530	510/530	500/520
26	Lowering Speeds (laden/unladen)	mm/s	<600/ > 300		
27	Max. Draw-bar pull (laden/unladen)	kN	54		
28	Max. Negotiable Gradient (laden/unladen)	%	38/19	35/19	32/19
29	Battery (voltage/capacity)	V/Ah	2x12/80		
30	Tyre Type (front/rear)		Pneumatic		
31	Tyre Size (front)		8.25-15-14PR		
32	Tyre Size (rear)		8.25-15-14PR		
33	Service Mass	kg	8130	8720	9320

## Engine

34	Internal Combustion Engine Model		ISUZU 6BG1		
35	Engine Type		Diesel Engine		
36	Engine Rated Output	kW/rpm	8.23/2000		
37	Engine Rated Torque	Nm/rpm	418/1500		
38	Engine Displacement	L	6.49		
39	Engine Fuel Tank Capacity	L	110		
40	Transmission Number of Speed Fwd/Bwd Type		2/2 Power Shift		

## Engine Model and Main Specification for Optio

Internal Combustion Engine Model	Engine Type	Internal Combustion Engine Rated Output (kW/rpm)	Internal Combustion Engine Rated Torque (Nm/rpm)	Internal Combustion Engine Displacement (L)	Internal Combustion Engine Number of Cylinder
CHAO CHAI 6102	Diesel Engine	80.9/2500	353/1650	5.785	6

CPCD50 CPCD60 CPCD70 CPCD75

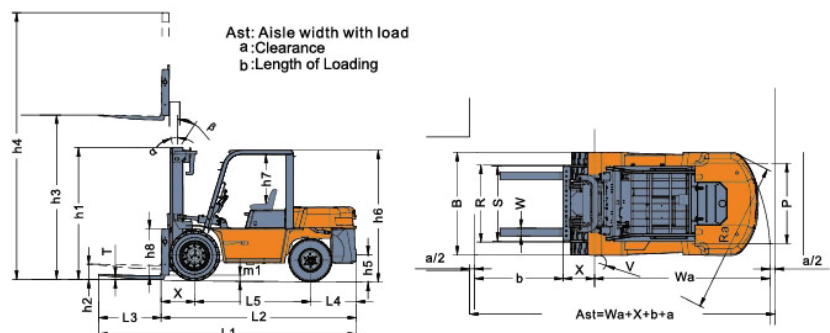
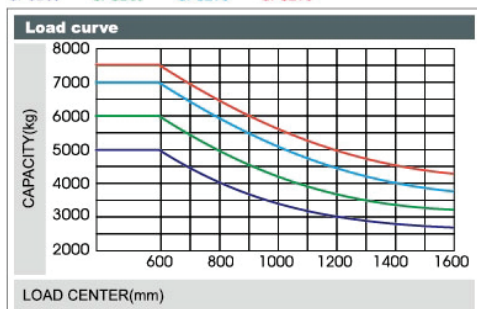

\*Details of specifications and equipment are based on information available at time of printing and may change without notice

AUTHORIZED DEALER